

VERTICAL SECTION

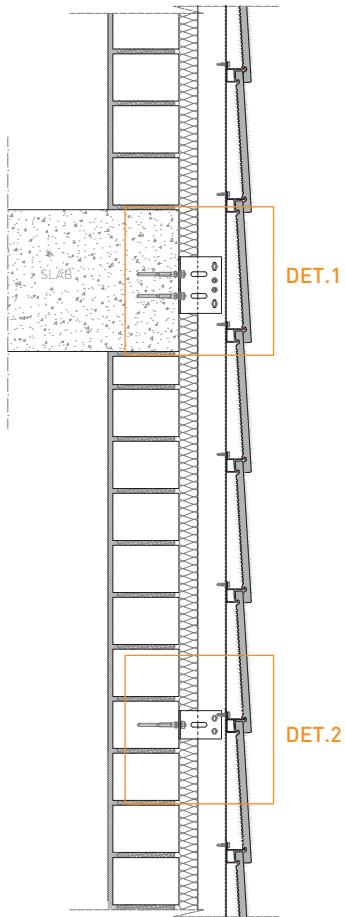

HORIZONTAL SECTION

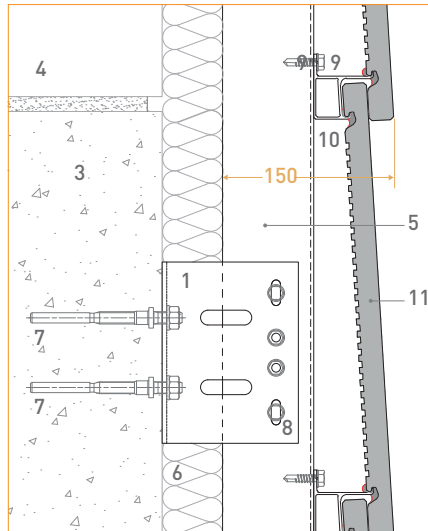
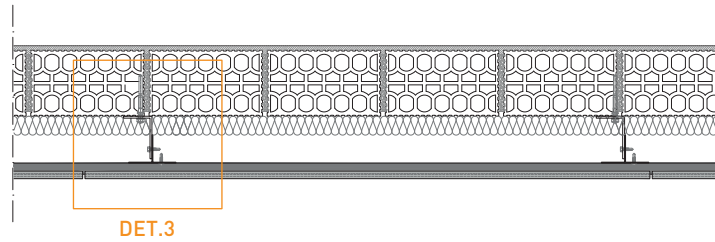

1. Support bracket

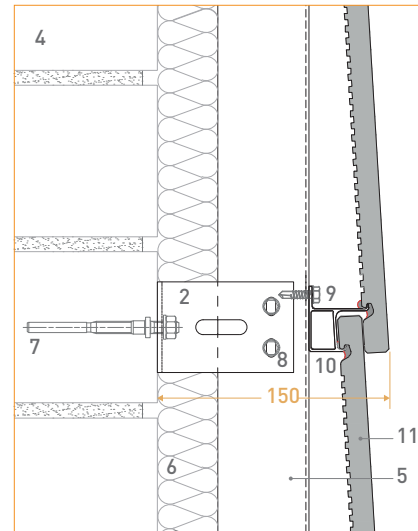

2. Stop bracket

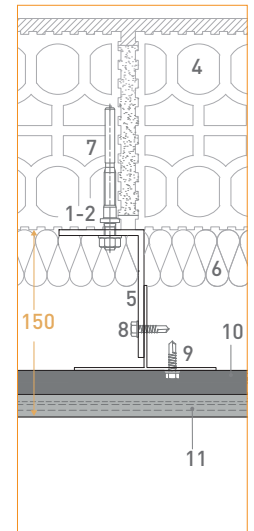

3. Horizontal detail

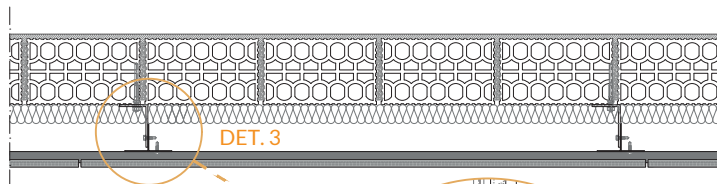

HORIZONTAL SECTION

scale: 1/8

LEGEND:

1. SUPPORT BRACKET
2. STOP BRACKET
3. SLAB
4. WALL
5. VERTICAL ALUMINUM PROFILE (PFC)
6. INSULATION
7. PLASTIC ANCHOR
8. AUTOSCREW N12 5.5X25 WITH WASHER
9. AUTOSCREW N12 5.5X22 WITHOUT WASHER
10. HORIZONTAL ALUMINUM PROFILE (PFF)
11. FAVETON CERAMIC TILE

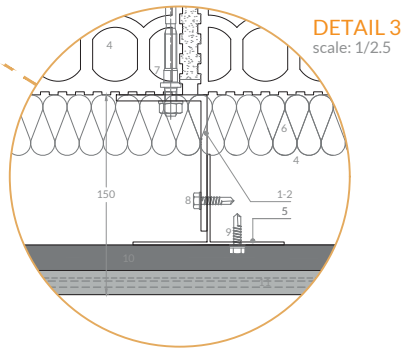

DETAIL 3
scale: 1/2.5

VERTICAL SECTION

scale: 1/8

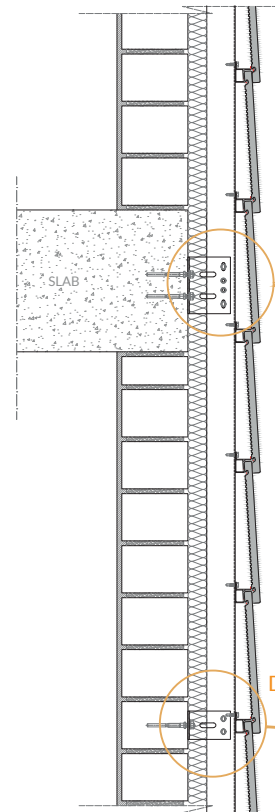

DET. 1

DET. 2

DETAIL 1
scale: 1/4

DETAIL 2
scale: 1/4

